

Harmonic mitigation

Solution Handbook

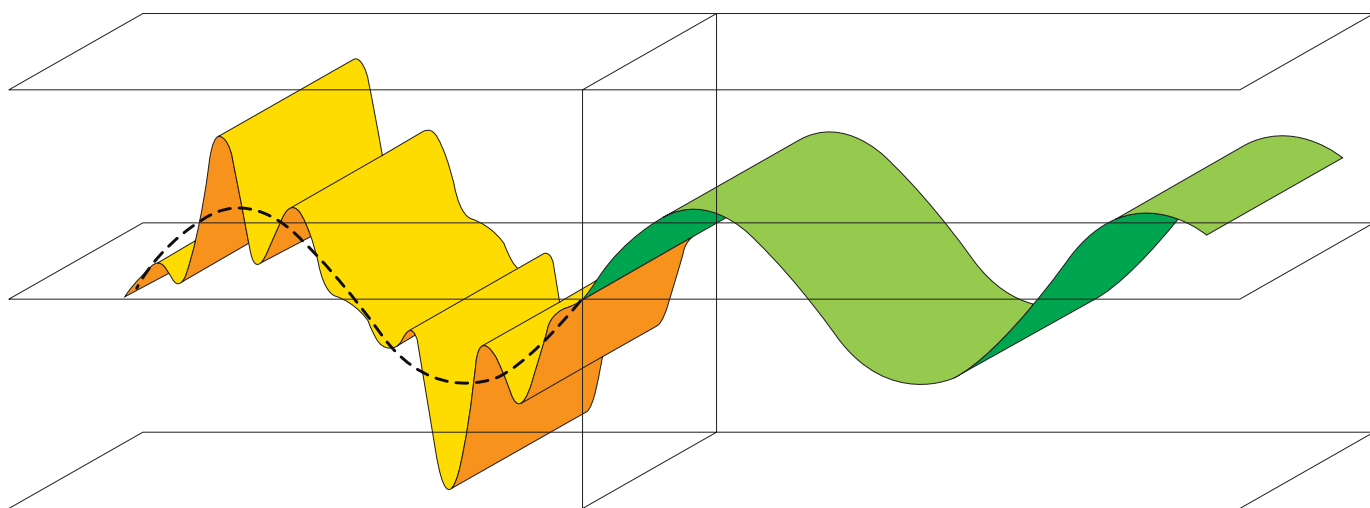

Index of contents

Introduction	3
Harmonics: origin & consequences	4
Benefits of Harmonic mitigation	5
Product offer.....	7
Schneider Electric solutions	11
Solutions for a new installation	12
Solutions for existing installations	16
Solutions for a machine	26
To know more	27
List of documents	33

Introduction

Harmonics are a growing concern in the management of electrical systems today. Designers are requested to pay more and more attention to energy savings and improved electricity availability. In this context, the topic of Harmonics is often discussed but there is still a need for more explanation, in order to dissipate confusion and misinterpretation.

The objective of this guide is to clarify the issue and demonstrate how the business performance of professional customers can be improved by **Harmonic Management**. Significant savings are achievable along with improvement of the electrical energy quality, thanks to the selection of adapted harmonic mitigation solutions.

This guide will assist you:

- To understand the **basics and effects** of harmonics in the electrical systems,
- To interpret the applicable **standards and regulations**,
- To know the comprehensive **Schneider Electric offer** for harmonic mitigation,
- To be able to adopt the best available solutions, based on optimum economical solution related to Capex and Opex, in addition to improved **Energy Efficiency**.

The following **key questions** will be reviewed:

- How to design a **new installation** taking harmonics into consideration, with high expectations relative to **Energy Efficiency**?
- How to put an **existing installation** in compliance to a **harmonic emission standard**?
- Which solution to adopt for **extension** of an existing installation?
- Which solution should be adopted when **connecting a non linear load** (e.g.: Variable Speed Drive)?
- How to improve **Energy Efficiency** by Harmonic management?
- Which solution to adopt for connection of **Power Factor Correction** capacitors in an existing installation?
- How to design a **machine** that includes non linear circuits in order to comply with harmonic emission limits?

There is generally more than one solution for a given industry segment or application. That's why the local operating conditions have to be analyzed before the best offer can be worked out. Teams of Schneider Electric specialists in your country are ready to assist you whenever necessary, for deeper on site analysis and solution implementation.

Technical information is available in the chapter "**To know more**" at the end of this document. **Definitions** of terms such as **THD, PCC, TDD...** are given. Information is given on the **applicable standards**. A list of relevant documents is proposed, as well as website addresses.

Harmonics: origin & consequences

The presence of harmonics in electrical systems means that **current and voltage are distorted** and deviate from sinusoidal waveforms.

Harmonic currents are caused by non-linear loads connected to the distribution system. A load is said to be non-linear when the current it draws does not have the same waveform as the supply voltage. The flow of harmonic

currents through system impedances in turn creates voltage harmonics, which distort the supply voltage.

On the following pictures are presented typical current waveforms for single-phase (top) and three-phase non-linear loads (bottom).

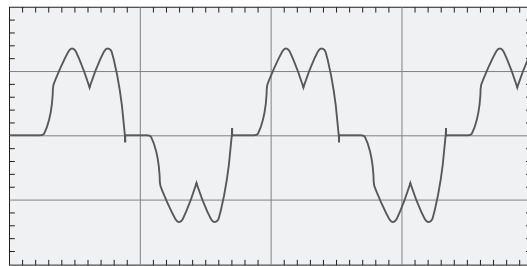
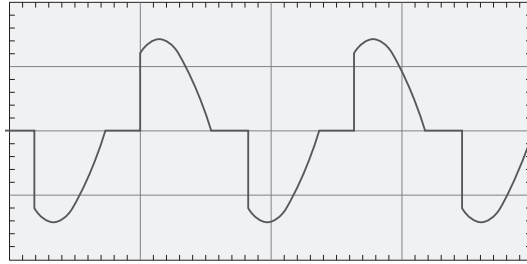
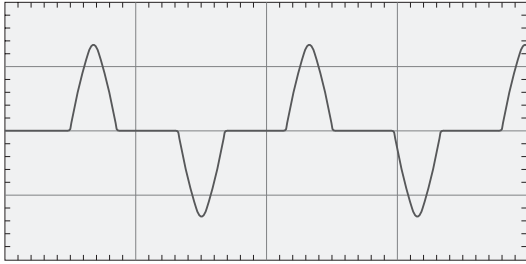

Equipment comprising power electronics circuits are typical non-linear loads. Such loads are increasingly frequent in all industrial, commercial and residential installations and their percentage in overall electrical consumption is growing steadily.

Examples include:

- Industrial equipment (welding machines, arc and induction furnaces, battery chargers),
- Variable Speed Drives for AC or DC motors,
- Uninterruptible Power Supplies,
- Office equipment (PCs, printers, servers, etc.),
- Household appliances (TV sets, microwave ovens, fluorescent lighting, light dimmers).

The major consequences of harmonics are the increase of the r.m.s. current in the different circuits and the deterioration of the supply voltage quality. The negative impact may remain un-noticed, with economical adverse results.

That is why a proper harmonic mitigation will contribute to improve competitiveness of companies in different ways:

- Reduced overloading on the electrical system, thereby releasing useable capacity,
- Reduced system losses and demand power,
- Reduced risks of outage,
- Extended equipment lifetime.

The total harmonic distortion THD is the usual parameter to evaluate the level of distortion of an alternating signal (see definition in "To know more"). The voltage distortion THD_u is usually considered at the installation level, while the current distortion THD_i is usually considered at the non-linear equipment level.

Benefits of Harmonic mitigation

- Up to 25% Capex and Opex reduction commonly achievable,
- Improved business performance: downtime significantly reduced, increased equipment lifetime.

Harmonic mitigation provides several benefits that could be translated into financial savings for the investor and for the user.

We propose solutions which maximize the savings when balanced with the cost of the harmonic mitigation equipment to get a reasonable Return On Investment (ROI).

In order to illustrate the benefits, we will take the example of the following installation with two different situations.

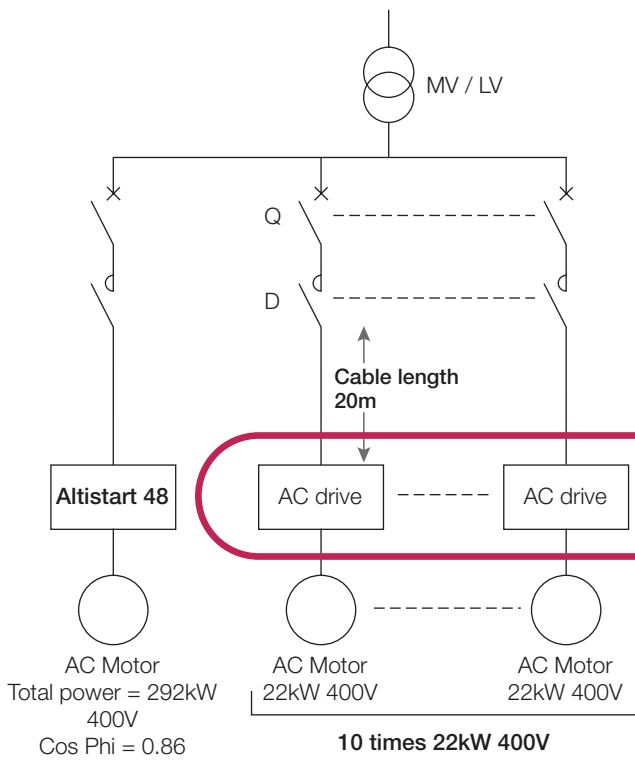

Either

Or

AC drives standard type

Line current waveform (6 pulses):

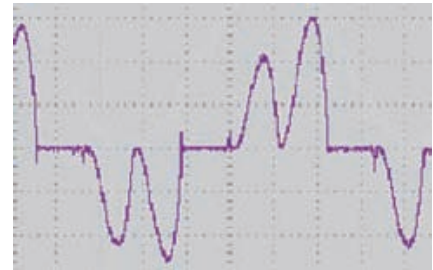

Maximum line r.m.s. current = 60A

Altivar 21

Line current waveform with C-Less technology:



Total harmonic distortion: THDi = 35%

Line r.m.s. current = 38A

In both cases, the transformer is chosen to keep the Total Harmonic Voltage Distortion THD_u below 5%.

Usage and simultaneity factors have been taken into account for convenient sizing of equipment.

Benefits of Harmonic mitigation (continued)

Reduction of the capital expenditures (Capex)

Saving on Capex is the permanent concern of the investor. Harmonic management gives the opportunity of significant savings. We will focus on the cost of equipment and will not quote other savings such as space savings or labour costs.

Harmonic mitigation reduces the r.m.s. value of the current and so reduces the size of cables, the rating of circuit breakers and contactors, as summarized in the following table.

In our example, the total Capex for the global installation has been reduced by 15%.

	Without mitigation	With mitigation	Capex difference
Drive line current	60A	38A	
Transformer	800 kVA	630 kVA	-11%
Cables	16 mm ²	10 mm ²	-43%
Circuit breakers	NS80HMA80	NS80HMA50	-9%
Contactors	TeSys D50	TeSys D32	-40%
Total			-15%

Reduction of the operating expenses (Opex)

Opex will be impacted in different ways:

- Harmonic mitigation generally contributes to reduced power losses in transformers, cables, switchgear... The maximum savings should be obtained considering the same equipment ratings. In the example given here, the energy savings are less significant compared to the annual power consumption, because the advantage of lower currents has been counterbalanced by higher impedance of the selected smaller transformer and cables.
- Harmonic mitigation allows reducing the subscribed power to the energy supplier.

This saving depends on the energy supplier. In most of the cases, savings could be up to 10% of the electricity bill.

In the given example, the annual savings on Opex is 4500€.

Improved business performance

Harmonics are responsible for increased line currents, resulting in additional power losses and increased temperature in transformers, cables, motors, capacitors...

The consequence may be the unwanted tripping of circuit breakers or protection relays, and a reduced lifetime of equipment.

For example, an increase of 10°C of the operating temperature of a motor will result in a lifetime reduction by 50%.

The cost of maintenance and repair may be significant, but still relatively low compared to the financial losses linked to a process interruption.

Here are some examples of over cost related to undesirable events on the electricity supply in some high value added industries.

Industry	Financial losses per event
Semiconductor wafer processing	3,800,000 €
Financial company	6,000,000 € per hour
Data centre	750,000 €
Telecommunication	30,000 € per minute
Steelworks	350,000 €
Glass industry	250,000 €

The related downtime and financial consequences may be drastically reduced by proactive actions including harmonic mitigation.

Product offer

Schneider Electric is specialised in harmonic mitigation objectives and is therefore offering a broad range of solutions for every demand. The right choice is always dependent on a variety of factors, but Schneider Electric is ready to supply a convenient and optimised solution for our customer needs.

The following list gives a short description of the harmonic mitigation solutions available.

C-less technology

This technology combined with the advanced control algorithm decreases the THD_i down to 35%. This solution has been adopted for Altivar ATV21 which is dedicated to centrifugal pumps, fans and HVAC machines.



AC-Line or DC-link chokes for Drives

They are commonly used up to about 500kW unit power or 1,000kW total drives power. In this power range the transformer should be at least 2.5 times the drives load. Depending on the transformer size and cabling, the resulting THD_u will be up to ~6%. This could give possible nuisance, but is usually well accepted in industrial networks.

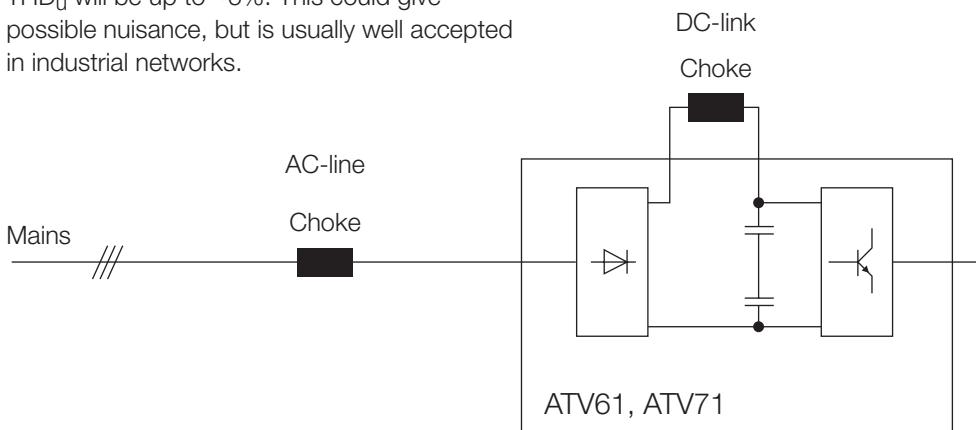

If AC-line or DC-link chokes are not sufficient for a large drive, a multi-pulse arrangement is the next step to consider.

When a large number of drives are present within an installation, the use of AC-Line or DC-link chokes for each individual drive is recommended. This measure increases the life time of the drives and enables use of cost effective mitigation solutions at installation level, such as active filters for example.



Product offer (continued)

Multi-pulse arrangement

This is usually used for drives above 400 kW, but could also be reasonable for smaller power ratings. Precondition is a dedicated transformer directly supplied from the MV network. Standard is the use of a 3-winding transformer providing a 12-pulse supply for the drive. This limits the harmonic emission considerably

and usually no further mitigation is necessary. Besides, multi-pulse solutions are the most efficient in terms of power losses. Compliance to IEEE-519 is also easily achievable.

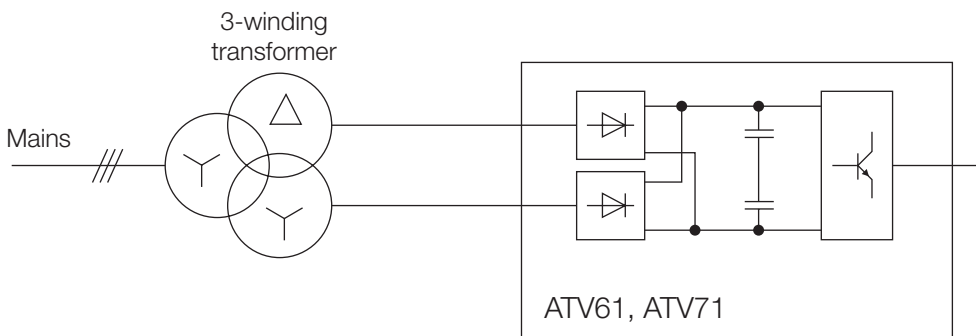

18- and 24-pulse configurations are also commonly used in some countries.

Solutions including capacitor banks

When capacitor banks are requested for Power Factor Correction, two parameters are considered if available:

- G_h : total power of the non-linear loads,
- S_n : rated power of the supply transformer.

Different types of equipment can be selected depending on the level of the network harmonic emission. The selection is based on the value of the G_h/S_n ratio, as illustrated on the following figure:

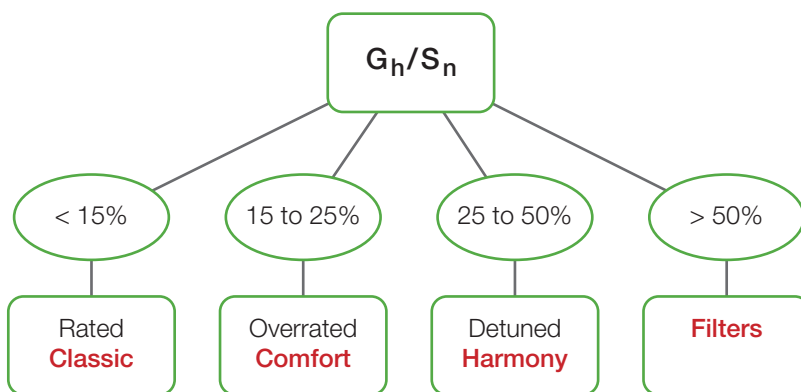

Passive filters consist of reactors and capacitors set up in a resonant circuit configuration, tuned to the frequency of the harmonic order to be eliminated. A system may be composed of a number of filters to eliminate several harmonic orders.

Characteristics of the VARSET range:

- Supply Voltage: 400V/50Hz,

- up to 265 kvar (382A @50Hz) / 470A for the 5th harmonic,
- up to 145 kvar (210A @50Hz) / 225A for the 7th harmonic,
- up to 105 kvar (152A @50Hz) / 145A for the 11th harmonic.

Other voltage and reactive power are available on request.

Active Front End (AFE)

An AFE is the best performing solution concerning harmonic mitigation, limiting the THDi below 5%. All the applicable standard requirements can be met. No detailed system evaluation is necessary, making this solution the easiest to implement.

In addition to harmonic mitigation, power regeneration and power factor correction are inherent.

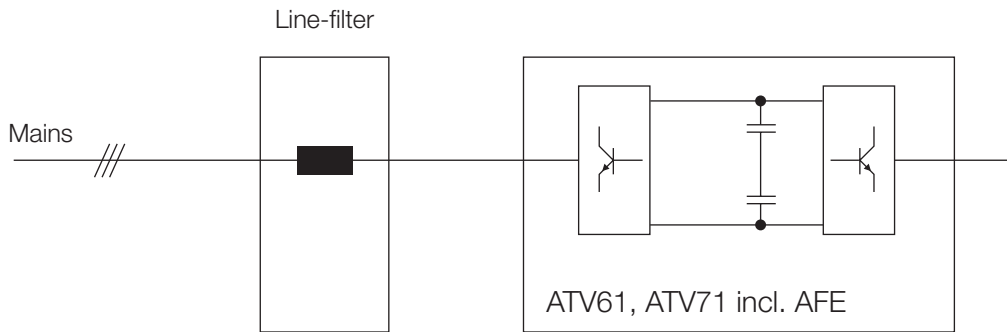

Active filters

Schneider Electric can propose 3 different ranges of active filters: SineWave, AccuSine, and Accusine Engineered Solution, which cover a large extent of customer needs (range names may differ from one country to another). Their main characteristics are summarized below.

SineWave

- Three or four wire connection (3 phase or 3 phase + Neutral),
- 400 V supply,
- Units from 20A to 120A, with possible parallel operation up to 480A,
- Cancellation up to the 25th harmonic.



AccuSine

- Three wire connection,
- From 230 V to 480 V supply (higher voltage level possible with transformer),
- Filtering at network level, units from 50A to 300A, with possible parallel operation up to 3000A,
- Cancellation up to the 50th harmonic

AccuSine Engineered Solution (ES)

- Three wire connection,
- From 230 V to 480 V supply (higher voltage level possible with transformer),
- Filtering at network level up to 3000A,
- Cancellation up to the 50th harmonic,
- Possible correction of individual harmonics,
- Advanced Human Machine Interface (HMI).



Product offer (continued)

Offer positioning

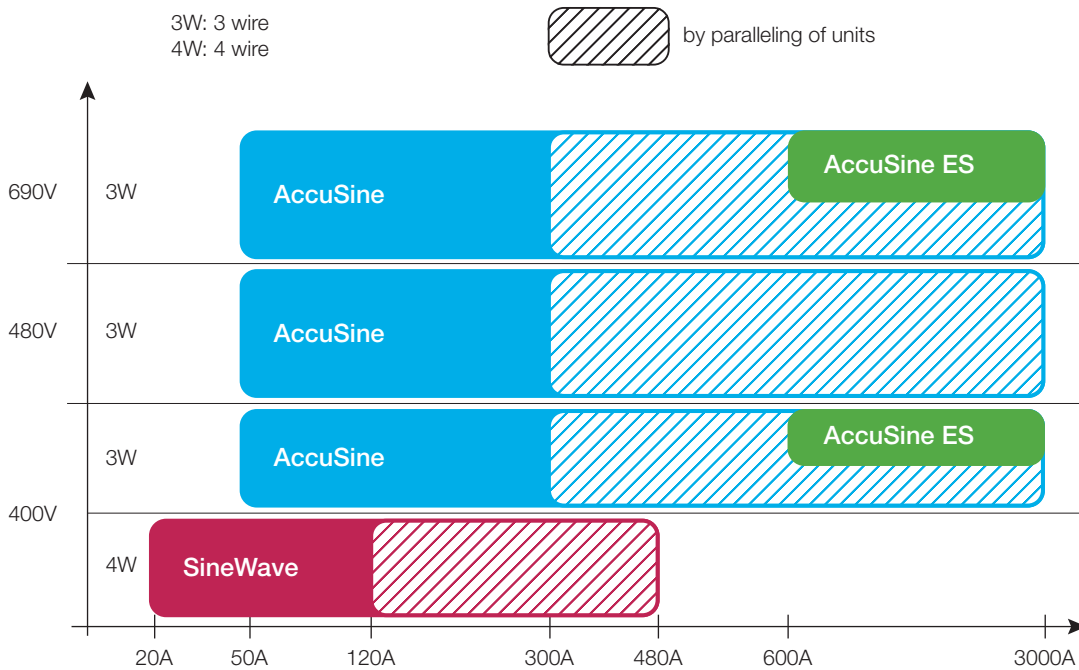

Hybrid filter

A hybrid filter is a system including a passive filter tuned on the 5th harmonic and a SineWave active filter in a single unit.

Main characteristics:

- supply voltage: 400V,
- Passive filter tuned to the 5th harmonic order,
- Active filter rated current: 20 to 180A,
- Reactive energy compensation: up to 265 kvar,
- Total harmonic current: up to 440A.



Schneider Electric solutions

At installation level

At the installation level, the type of adapted filter has to be defined first, and then the adapted product or solution has to be selected according to the customer's needs.

The selection of the filter technology is based on 2 parameters:

- Requirement for reactive energy compensation (improvement of Displacement Power Factor, $\cos\varphi$),
- Maximum harmonic order to be treated.

When the DPF is lower than 0.85 – 0.9, a passive or hybrid solution is preferred.

The proposed selection is represented on the opposite diagram.

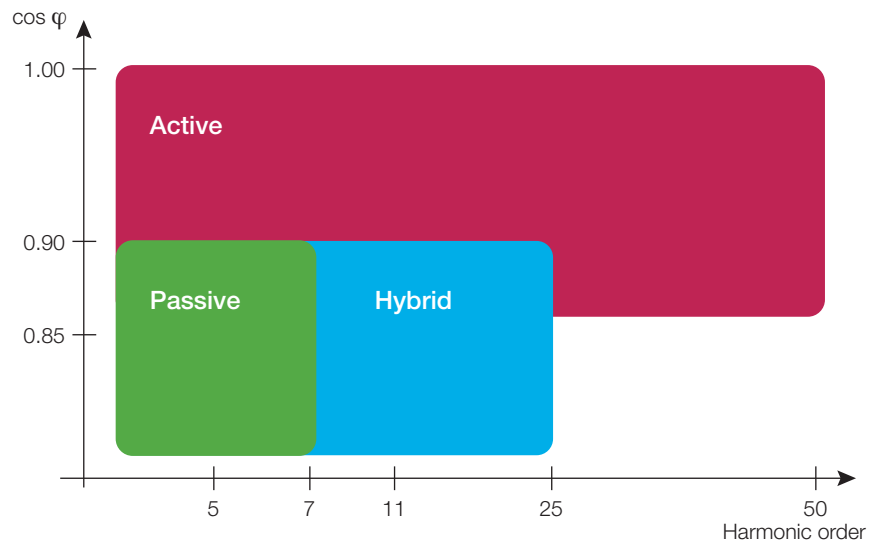

At equipment level

The different solutions proposed by Schneider Electric are presented on the opposite chart in terms of power and achievable current distortion (THD_i).

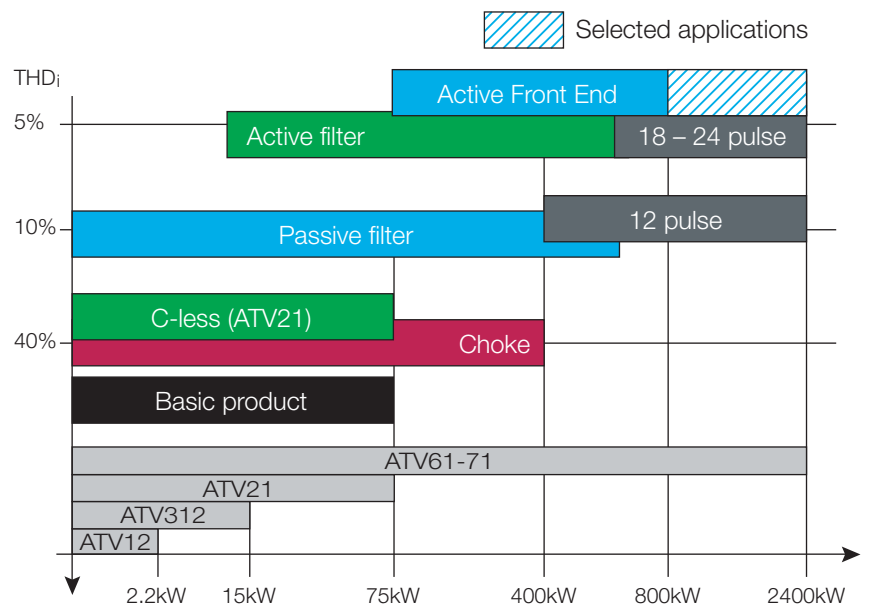

On the opposite chart is presented an overview of harmonic mitigation solutions based on efficiency and price.

The scale on the X-axis is representative of the total price of the drive plus the associated mitigation equipment.

Active and passive filters are plotted on the above chart as solutions implemented at equipment level. Their competitiveness is improved when they are implemented at network level.

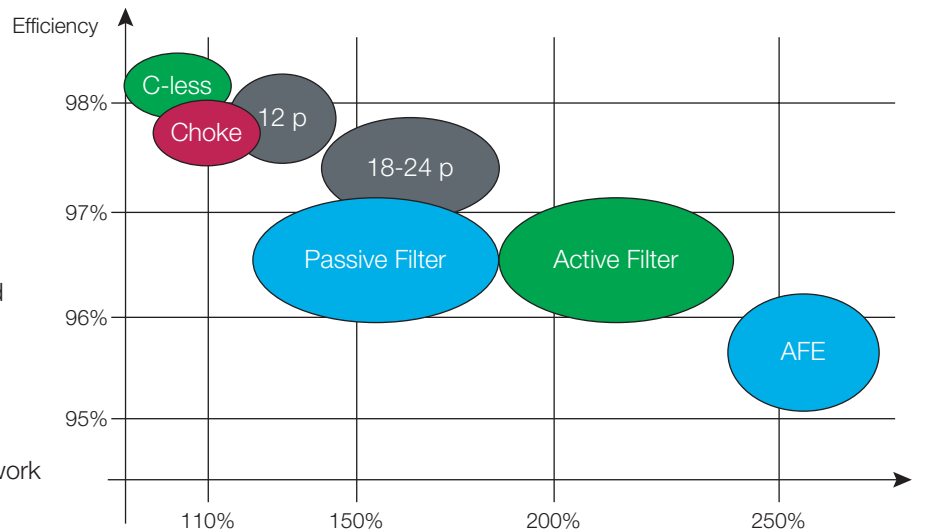

Solutions for a new installation

- How to design a new installation taking harmonics into consideration, with high expectations relative to Energy Efficiency?

Parameters to be considered

The design of new installations gives the opportunity to perform harmonic assessment optimizing Capex and Opex.

Generally the design of a new installation will be the responsibility of a designer or contractor. They are professionals familiar with taking into account several aspects during the design phase, with two main priorities:

- What shall be done for compliance with applicable standards?
- Which is the most reasonable solution with respect to Capex and Opex?

In order to manage harmonics effectively, the following parameters shall be considered:

Network parameters

It is important to know the network parameters to be able to qualify the conditions at the Point of Common Coupling (PCC). The system size (known by power or impedance) and topology both have an influence on the resulting harmonic distortion.

Activity sector

The applicable standards differ depending on the activity sector of the new installation. For example, relevant standards in residential, commercial or light industry sectors are generally applicable to pieces of equipment. On the other hand, standards or regulations applicable in industrial sectors are requested by the Utilities and applied to global installations. Then, some attenuation factors can be taken into account and central mitigation is generally more cost effective.

Applicable harmonic standard

Knowing the segment and the network parameters, the applicable standards should be determined. Applying the relevant standard is one of the most important decisions. Selecting limits that exceed the standard requirements will lead to unnecessarily high investment and possibly increased operating costs.

On the other hand, application of relaxed limits can result in high energy and maintenance costs, as well as disturbances on the mains.

Project drivers

Whenever an investment is necessary, it is important to set a priority concerning the project drivers. A solution optimised for a low Capex may be pretty expensive for Opex and vice versa. The requested performance for a solution has also an influence on Capex and Opex.

Reactive Energy penalties applicable

The subscription contract with the energy supplier also has an influence on the design of the installation. If penalties are applicable for exceeding reactive energy limits, the implementation of Power Factor Correction capacitors should be considered. However, if harmonic current generators and capacitor banks are present, current and voltage distortions may be amplified (resonance phenomenon). This has a significant impact on the resulting harmonic distortion. PFC and Harmonic mitigation must be studied together and additional precautionary measures may need to be taken.

Ratio: non-linear load power / total load power

The higher the share of non-linear loads compared to the total load power of an installation, the higher is the necessity for a close attention and evaluation of the harmonics influence.

Guidance for a solution

For a new installation, the first step is to evaluate the global situation, select the corresponding standard and determine if mitigation is necessary or not. The activity sector, the network parameters and the power of non-linear loads have to be considered.

Here are the major recommendations:

- If harmonic mitigation is necessary, **global mitigation** should be considered first. This is because single large mitigation equipment at the installation level is usually more cost effective than several small ones at equipment level.
- When **large drives are present**, ($\geq 400\text{kW}$), local mitigation is recommended. Typical

solutions include multi-pulse configurations, Active Front End (AFE), and active filter.

- When a **large number of drives are present**, the implementation of chokes is recommended (AC-line or DC-link chokes).
- When **PFC capacitors are present**, detuned banks should be preferred, with active filter if further attenuation is needed. This will ensure capacitor protection and avoid resonance.
- When **PFC capacitors are not present**, an active filter is the preferred solution.

The following diagram indicates in which situation the different solutions are the best adapted.

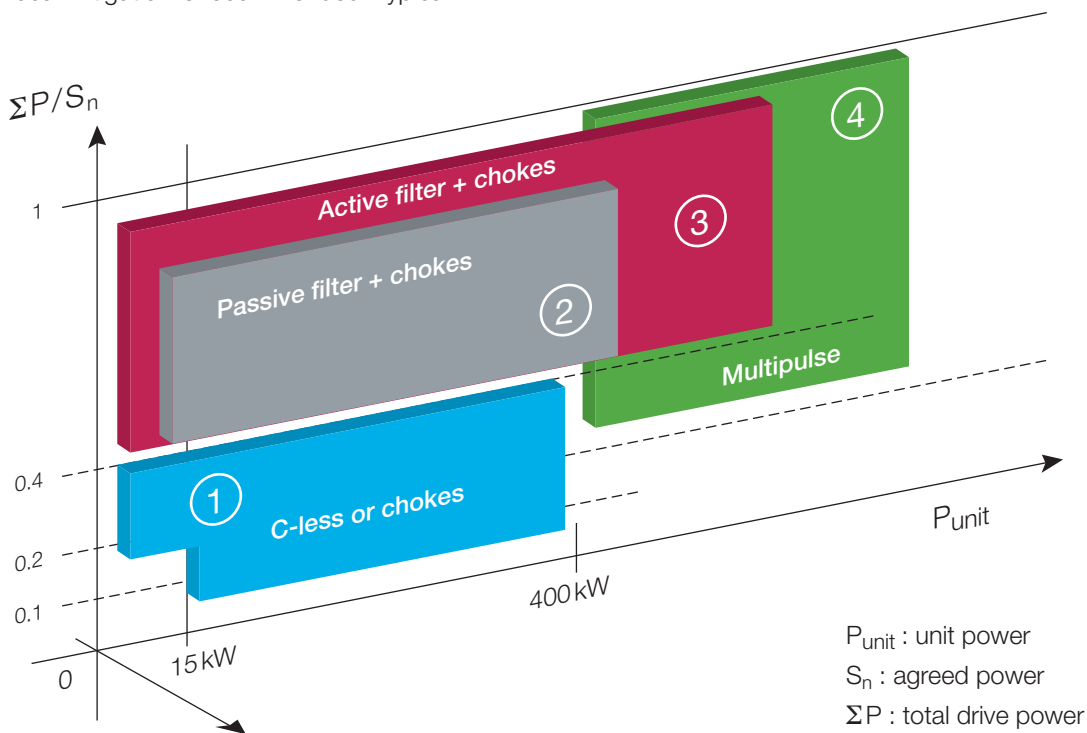

The two considered criteria are the unit power of the installed drives (P_{unit}), and the ratio of the total power of drives (ΣP) related to the agreed power of the installation (S_n).

- **Area 1:** C-less technology or chokes are the best solution. Chokes can be embedded or not in the drives. C-Less drives do not require any choke.
- **Area 2:** Drives represent a significant part of the total power. A filter is necessary, in conjunction with chokes. A passive filter is well adapted when Power Factor Correction is necessary (low value of $\cos\phi$).

● **Area 3:** Drives represent a significant part of the total power. An active filter is well adapted when no PFC is necessary. AFE is applicable for large drives.

● **Area 4:** For drives of typically 400 kW and above, a multi-pulse solution at equipment level is more convenient in the majority of cases because of better efficiency (up to 3% improvement compared to additional filter: active, passive, or active front end solution). In addition, a multi-pulse arrangement is usually more cost effective than other solutions.

Solutions for a new installation (continued)

Example: Managing Harmonics and resonance with AccuSine Active Harmonic Filters (AHF) in an offshore ring main oil field

An international oil company planned the construction of a number of offshore oil platforms to conserve generator fuel. This was designed by installation of a 33 kV undersea cabling system between the platforms.

This resulted in large voltage resonance potential, linked to the presence of AC and DC motor drives at both MV and LV levels.

The entire ring is 150 km in length. The total capacitive reactance was calculated to cause resonance at the generators between 250 and 550 Hz for this 50 Hz system. Additionally, the frequency will shift according to the load levels and mix of loads operating. The predicted THD_u on a number of platforms at the 600 Vac distribution bus was close to 15%.

The first level of mitigation is the addition of line inductance at the drives input. This provides extremely large gains in harmonic current reduction. An additional benefit of adding inductance at the input of DC drives is the reduction of the voltage notch. The notch is greatly reduced in depth resulting in lower to no severe effects on other products.

After considering a number of harmonic mitigation technologies, full spectrum AccuSine AHF were selected for the following reasons:

- Speed of operation (100 μ s real time performance),
- All non fundamental currents treated (not just characteristic harmonics),
- Significant further reduction in line notching,
- No addition of capacitors that enhance resonance from the 33 kV ring main system.

Four 300A AccuSine AHF were connected in parallel with the six 800HP DC drives of the drilling package, with one additional 300A AccuSine AHF connected to the 900HP AC drive.

With the AHF switched on, the THD_i at the 600 V bus is reduced from 35% to 3.7%.

Of particular significance are the reductions of the 5th harmonic current amplitude from 232A to 11A (95.4% removal) and the 7th harmonic current amplitude from 72A to 11A (84.3% removal) as well.

The 11 kV THD_u is limited to 4.1%.



Example of AccuSine ES active filter implementation

The windy conditions in the Austrian Alps have been the reason for building a new wind farm in the "Niedere Tauern" in Styria in 2002. By the way, this is the highest situated wind park in Europe. The average wind speed is 7m/s which is comparable to the wind conditions on the North Sea. The wind mills have been installed on the top of a mountain in a very exposed position. This exposure to environment also requires a 21km branch line to the substation, which is realized by underground cable.

During commissioning, it was found that the generators in combination with the long

cable create resonance on the system. This unforeseeable condition required compensation of certain harmonics.

This was the right task for AccuSine ES, which is able to be set up for correction of individual harmonics. Thereby AccuSine ES is connected to the mains on the 33kV MV side of the substation via a transformer.

Thanks to the adjustable compensation of AccuSine ES, it was not necessary to redesign the topology of the wind mills connection and to use the installation with full design power as planned.

Schematic diagram

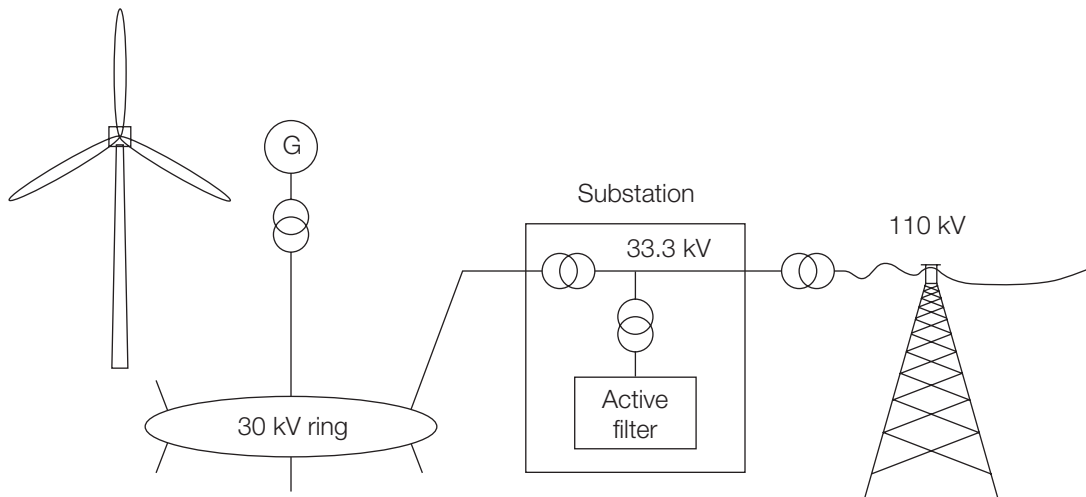

The AccuSine ES active filter is installed inside a container:

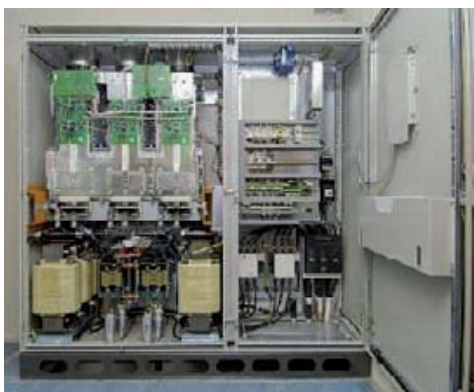

"Niedere Tauern" wind park project at a glance:

- Project name: Windpark Oberzeiring
- Customer name: Tauernwind
- Contractor: ELIN EBG
- Success factors:
 - Adjustability of individual harmonics,
 - Staff expertise,
 - Customer intimacy.

Website: www.tauernwind.com



Solutions for existing installations

● How to put an existing installation in compliance to a harmonic emission standard?

Regarding harmonics, the purpose of standardization is to ensure that the voltage distortion at the PCC is kept sufficiently low, so that other customers connected at the same point are not disturbed. This is the basics of the concept of "Electromagnetic Compatibility" (EMC).

For **low power equipment** connected directly to the LV supply system, current emission limits given by international standards are applicable to pieces of equipment.

For **global installations**, emission limits are set by the Utilities based on the local applicable standards or regulations.

Generally, limits are established for the Total Harmonic Voltage Distortion (THD_u), the Total Harmonic Current Distortion (THD_i), and individual harmonic currents (I_h).

The main parameters taken into account are the **short-circuit power** S_{sc} of the supply system and the **agreed power** (or total demand power) of the customer installation.

The principle is to allow each customer to contribute to the global distortion, in proportion to the agreed power of the installation.

The global resulting distortion must be kept under certain limits, so that the Electromagnetic Compatibility can be ensured.

The application area of the main standards dealing with harmonics is presented on the following figure. A brief description of these standards is presented at the end of this document.

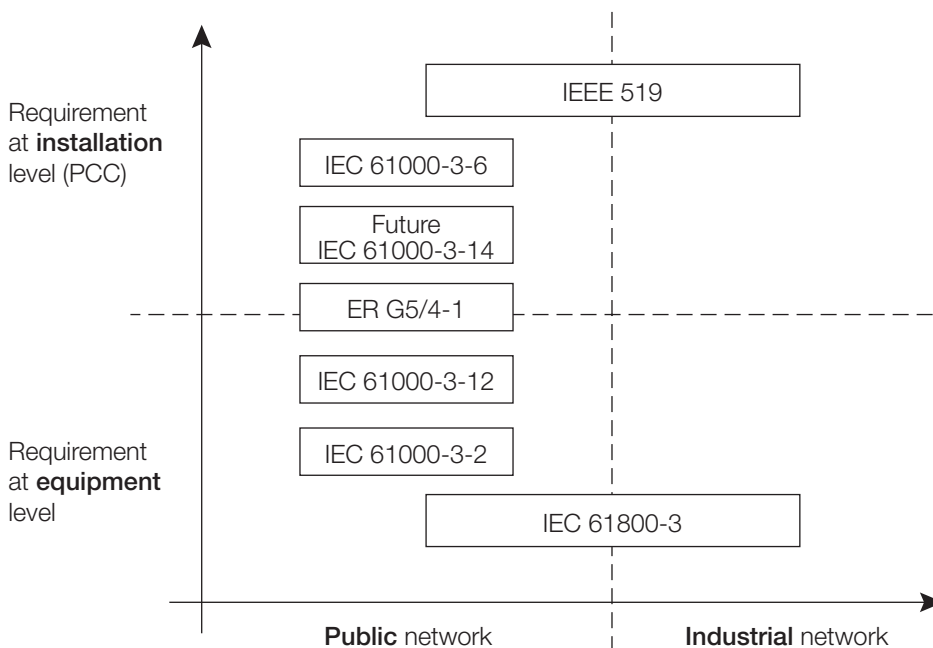

It should be noted that too stringent harmonic emission limits could become very expensive. That's why a careful application of standards should be performed. The following diagram is proposed for clarification.

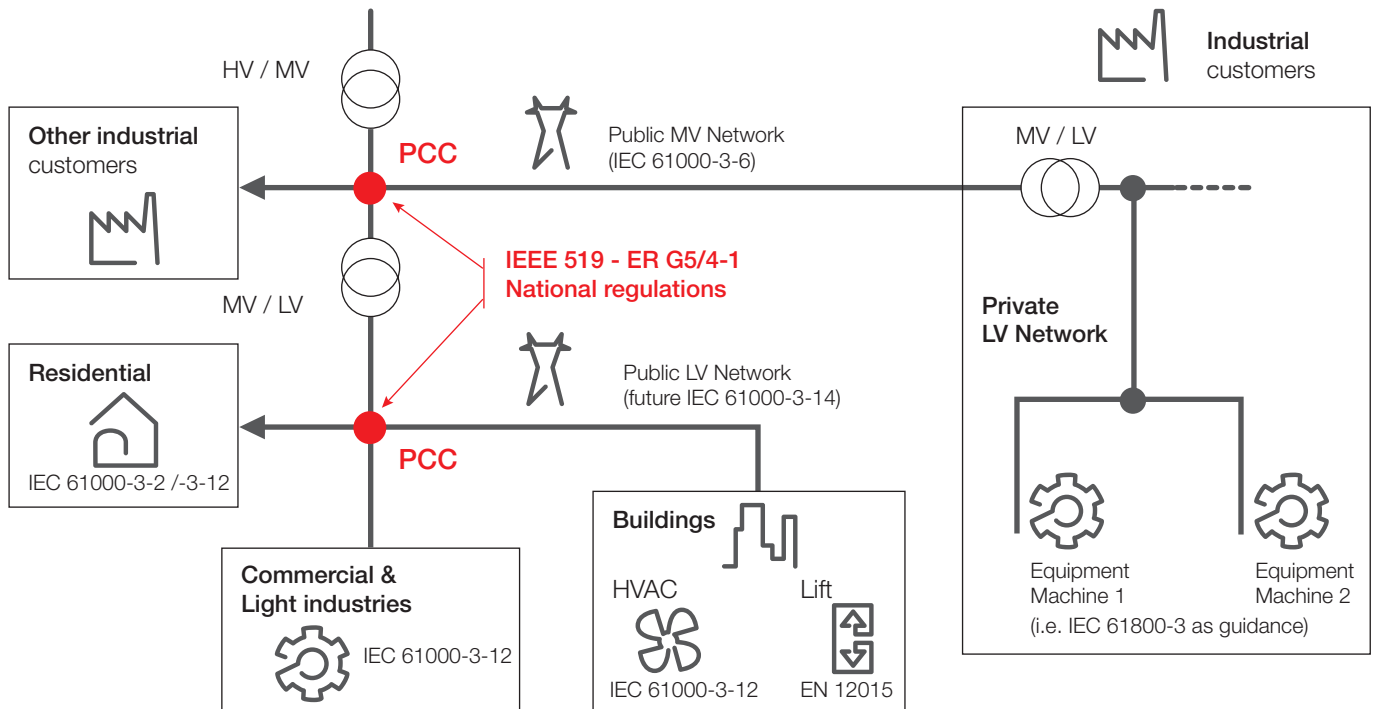

The THD_u limits are considered at the PCC within the public network (LV or MV) where the different customers are supplied by the Utility. Limits must be applied at the PCC in order to ensure the Utility (often by duty constraints) supplies the different customers with a good quality of power, i.e. with non distorted voltage. For LV customers, IEC 61000-3-2 and 61000-3-12 are harmonic emission standards

applicable at equipment level. THD_i and individual I_h limits are required for pieces of equipment up to 75A. Above this value, an agreement is usually needed between the Utility and the customer before connection.

Some local country regulations, based on other standards or codes (such as ER G5/4-1 or IEEE 519) should be considered when requested.

Guidance for a solution

Here are the major recommendations:

- Select the relevant emission limits (example: IEEE 519, ...)
- Perform an harmonic assessment as described in standards with consideration of the capacitor banks if any,
- If harmonic mitigation is necessary, **global mitigation** should be considered first. This is

because a single large mitigation equipment at installation level is usually more cost effective than several small ones at machine level.

- For large drives (unit power $\geq 400kW$): **local mitigation** is recommended. For example: Multi-pulse, AFE, Active filter. See diagram presented above, section "Solutions for a new installation".

Solutions for existing installations

Example of implementation of an active filter at a Waste Water Treatment Plant

A wastewater treatment plant installed Variable Frequency Drives (VFDs) to improve control of raw sewage pumps and to decrease operating costs through variable speed operation. A variety of unexpected problems occurred, including interference with the computer management system. Depending upon the speed of the VFD raw sewage pump system, the circuit breaker protecting the management control system would trip, shutting the plant down.

The downtime risk included the potential for partially treated sewage to be dumped into a nearby river.

Consultants were hired to analyze the situation. It was determined that harmonic control would be necessary to insure system integrity. First,

an input line reactor was installed and it was partially successful. However, the problem persisted when the system operated at near full load and speed conditions. Installation of an AccuSine active filter eliminated the problem completely.

This installation required an AccuSine rated at 50 amperes and 480 volts performing active harmonic control, canceling the harmonic current demanded by a VFD rated at 125 horsepower.

AccuSine successfully reduced the total harmonic current distortion (as defined by IEEE 519) from 39.0% to 4.1%, insuring trouble free operation of the plant. See the chart recordings below.

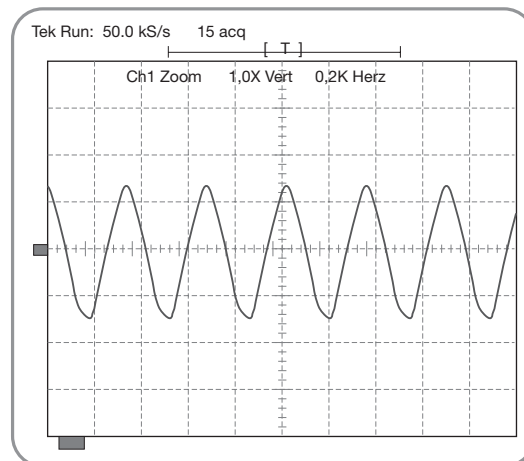
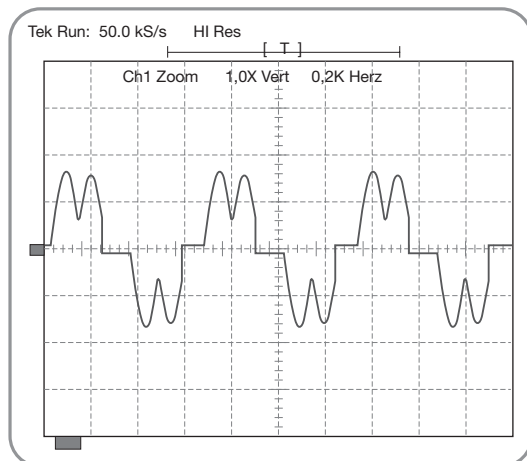

● Which solution is to be adopted for extension of an existing installation?

When an existing installation is extended, the same recommendations as given above apply.

Of course, all the different loads (existing and additional) on the network must be taken into account, as well as all harmonic mitigation solutions already installed.

Then, the suitable solution must be studied for the entire installation as for a new installation.

The following influent parameters must be checked:

- Type and size of currently installed harmonic mitigation solutions,
- Displacement Power Factor ($\cos \varphi$),
- Total harmonic distortion (THD_u and THD_i),
- Current harmonic spectrum.

If there is no significant modification of the influent parameters, the suitable harmonic mitigation solution will remain the same.

If an active filter is already present, the installation can be upgraded by the connection of an additional active filter in parallel.

Additional AC-line or DC-link chokes can be favourably implemented without further investigation.

Passive or hybrid filters can be kept unchanged if oversized and matching the new current requirements. Otherwise, they have to be redesigned, as the parallel connection of passive filters is not recommended. A slight difference in the tuning frequency may cause oscillations and overload.

The risk of overload of any PFC capacitor bank has to be checked carefully. If the capacitor bank is not equipped with detuned reactor, it is recommended to carry out a complete harmonic study.

Example of implementation of a Hybrid filter

A new chair lift has been installed at the ski resort of Valmorel, France, in 2007.

This equipment is driven by a 530 kW DC motor, supplied by an AC to DC converter.

On-site measurements of background distortion and simulations showed that harmonic mitigation was necessary in order to comply with Electricité de France regulations ("Arrêté du 17 mars 2003").

Estimated results:

- 5th harmonic voltage V_5 : 5.5%
- 7th harmonic voltage V_7 : 2.8%
- Total Harmonic Voltage Distortion THD_u : 7%
- Displacement Power factor: 0.8

The proposed solution is a **hybrid filter** with a 210 kvar 5th harmonic filter and a 60A SineWave active filter.

Measurement results after implementation:

- 5th harmonic voltage V_5 : 1.5%
- 7th harmonic voltage V_7 : 1.5%
- Total Harmonic Voltage Distortion THD_u : 2%
- Displacement Power factor: 0.95



Solutions for existing installations

- Which solution should be adopted for connection of a non linear load (e.g.: Variable Speed Drive)?

When a new piece of equipment is connected to an existing installation, it has to be checked if the connection is possible straightforward or if there are conditions to be taken into account. This is especially true for non-linear loads such as Variable Speed Drives (VSD) or Uninterrupted Power Supplies (UPS) for example.

There are two possible cases for the connection of a new VSD:

- The motor driven by the VSD did not exist before and thus it is an extension of the

network. In this case, of course, it has to be checked if the power is available from the supply system and the leads are sized for the additional current to be drawn,

- The motor driven by the VSD existed before, but was started using direct on line connection or a soft starter. In this case the power of the supply system and the leads will fit.

After this basic check, the examination of the harmonics can be started.

Guidance for a solution

The evaluation and selection of a suitable mitigation solution for non-linear loads can follow three successive steps:

Select the relevant harmonic emission limit (equipment or installation standard).

The first step is to identify if there is a standard to be applied and if yes, which one. Standards can either apply on equipment (limits applied on THD_i), or on the global installation (limits applied on TDD or THD_u). **Note that applying global installation harmonic limits at equipment level is not cost effective.**

For evaluating the influence on the system, the definition of the applicable PCC is very important. For most industrial installations, the PCC will be on the MV side of the supplying transformer.

If harmonic mitigation is needed or advisable, consider equipment mitigation first.

This will usually give the most cost effective solution.

- Total drives power **up to about 100kW:**

This power usually represents less than ~20% of the transformer rated power. The standard solution is to use AC-Line or DC-link chokes. These optional chokes reduce the THD_i value in the range of 35 to 45%. The resulting THD_u will therefore typically be from 2 to 3% and well accepted in most installations.

- Total drives power **from about 100 kW up to about 1,000kW**

In this power range, it is advisable to have the transformer power equal to at least 2.5 times the drives load. The standard solution is to use AC-Line or DC-link chokes. Depending on the transformer size and cable length, the resulting THD_u can be up to ~6%. This could give possible nuisance, but is usually well accepted in industrial networks.

- Total drives power **higher than 1,000 kW**

In this power range, drives are usually equipped with a dedicated transformer directly supplied from the MV network. A 3-winding transformer is commonly used, providing a 12-pulse supply for the drives. This considerably limits the harmonic emission and usually no further mitigation is necessary. In addition, multi pulse solutions are the most efficient in terms of power losses. Compliance to IEEE 519 is also easy to reach.

Check impact on existing equipment of installation

When a new non-linear load is connected to an existing installation, it has to be checked if it can have an influence on other components already connected on the same network. This is especially the case for capacitors and active filters.

- **Capacitors** are present

If capacitors are already present in the installation (Power Factor Correction or passive

harmonic filter), there is a risk of overload and resonance introduced by the additional harmonic currents.

Usually the supplier of the PFC or passive filter is able to evaluate the situation and should be contacted first.

● **Passive or hybrid** filter is present

The installed filter can be kept unchanged if it is oversized and can match the new current requirements. Otherwise, the passive element must be redesigned, as it is not possible to connect another element in parallel with exactly the same frequency tuning.

● **Active** filter is present

If an active filter is present, non-linear loads must always be equipped with line chokes. This will significantly reduce the harmonic current emission and thus the necessary current rating of the active filter.

No risk is introduced by the additional harmonic currents as the active filters are usually protected against overload. However, the cancellation of harmonic currents may not be totally effective, and the global performance may be deteriorated.

Usually the network designer is able to evaluate the situation and should be contacted first.

Example of implementation of a 12-pulse arrangement

The "Centre National de la Recherche Scientifique" CNRS in Grenoble, France, is the largest governmental research organization in France and the largest fundamental science agency in Europe. All together 30,000 people are working for CNRS as researchers, engineers, workers and administrative staff.

The cooling water demand of one of the research departments is covered by 3 pumps of 470kW each, whereas two are for normal operation and the third one is in standby for safety reasons.

For process improvement purposes, variable speed operation of the pumps has been decided and variable speed drives have been installed. Since the drives are non-linear loads which produce harmonic currents, harmonic mitigation was important to consider. On one side, the electricity supplier EDF required certain limits of THD_i to be kept. On the other side, all the scientific equipment should not be disturbed by low power quality. Therefore the decision was made to adopt a 12-pulse arrangement.

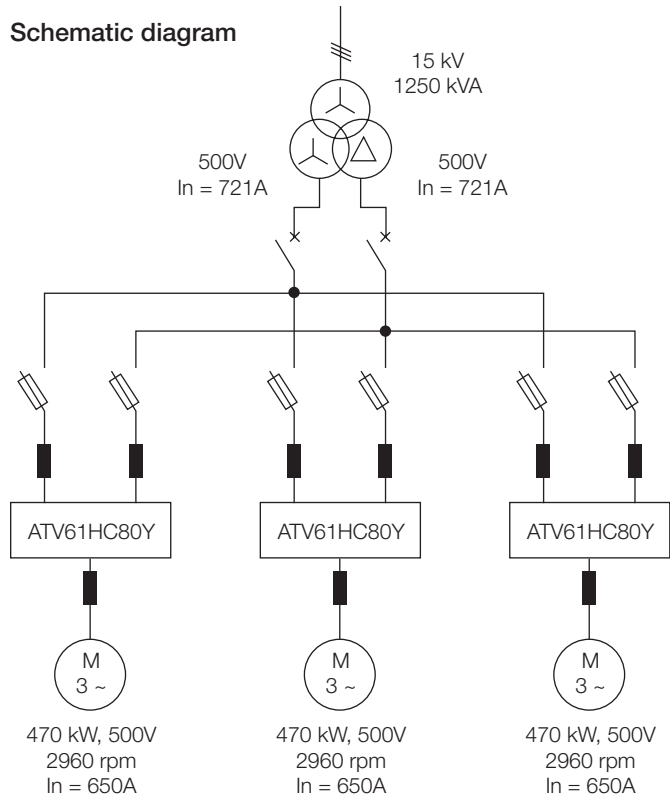

By choosing Altivar frequency converters, the benefits for the customer are that the drives are prepared for 12-pulse connection as standard and no additional equipment has to be ordered. Besides, Schneider Electric offered an "Engineered Drives" solution ready to use with all necessary components within proper cubicles.

The harmonic performance is within the expectation and all systems work properly.

Solutions for existing installations

View of the 3 cubicles



12-pulse solution at CNRS Grenoble at a glance:

- Project name: CNRS cooling water pumps
- Customer name: CNRS Grenoble
- Contractor: Schneider Electric, Project and Services
- Product: 3x ATV61HC80Y, 500V, 630kW
- Success factors:
 - 12-pulse connection as standard
 - Harmonic performance
 - Engineered Drives cubicle.

Internet: www.grenoble.cnrs.fr

Example: implementation of C-less technology in HVAC applications

AC Drives are now recognized by End User, Consultant engineers and mechanical contractors as a major contributor to energy efficiency in HVAC applications (pumps and fans).

Altivar ATV21 is the drive dedicated to HVAC. Its C-Less technology coupled with an advanced algorithm results in the lowest total harmonic distortion of the current (THD_i) compared to other technologies, while reducing Capex and Opex

Area TZB is a system integrator in Czech Republic that delivers complete equipment for buildings, from the design to the implementation.

Their requirements are:

- An optimized sizing of the electrical installation,
- Short commissioning time (proper operations of the installation without disturbances),
- Short implementation time of the equipments.

According to their experience, the requirements for the AC drives are:

- Low THD_i,
- Management of EMC inside the drive,
- Easy installation,
- Easy start-up.

After a first test in a building with 12 pieces of Altivar ATV21 with IP54 enclosure, Area TZB recognized that Altivar ATV21 fully meets their requirements.



● How to improve Energy Efficiency through Harmonic management in an existing installation?

In electrical installations, **Energy Efficiency** includes three different aspects:

- **Energy Savings:** reduction of energy consumption,
- **Energy Cost Optimization:** reduction of the cost of energy paid to the Utility,
- **Availability & Reliability:** minimize the risk of outage, and also sustain an efficient equipment operation.

Harmonic management has an impact on all 3 aspects, since it permits:

- Reduction of the **power losses** in transformers, cables, switchgear, motors, capacitors, by up to 5%,
- Reduction of the **demand power** (in MVA), resulting in lower tariffs,
- Use of the **total system capacity**, without risk of overload, nuisance tripping or premature ageing of equipment.

Guidance for solution selection

The selection of Energy Efficiency solutions can follow three successive steps:

Formulate priorities

Depending on the process requirements and site characteristics, different objectives must be set. For example, in a critical process industry, priority may be put on Availability and Reliability, to the detriment of cost optimization. In an office building, priority may be set on Energy savings.

Assessment of the current situation (at site level)

The next step consists of assessing the current situation, focussing on different indicators:

- Power factor,
- Harmonic distortion,
- Line currents (phase and neutral),
- Power demand.

Appropriate measurement devices installed at the head of the installation and on vital feeders provide the required information. It is then possible to evaluate the power losses related to harmonics, the possible reduction of power demand, and the possible improvement of reliability by eliminating the risk of nuisance tripping.

Consider efficiency and cost of different solutions

The last step of this approach includes the comparison of the different possible solutions, based on cost calculation, possible benefits and return on investment (ROI).

Solutions for existing installations

First example: Implementation of an active filter at offshore gas platform

First step: Priority

The action was initiated because a mechanical resonance of pump motors was responsible of production limitations. The set objective was to improve the **availability** of the system.

Second step: Assessment of the situation

Harmonic distortion was found responsible for the **mechanical resonance**.

Results of measurement: $THD_i \sim 30\%$,
 $THD_u \sim 10-12\%$

Third step: Selection of solution

An **AccuSine** active filter has been selected, based on cost and ease of installation.

Benefit: **Increased production** resulting in \$6000 additional income per day.

ROI: 4-5 days



Second example: Implementation of a 12-pulse solution for a pump application

First step: Priority

The flow regulation of a pump should get adapted to the demand of the process by means of a frequency converter. The overall objective is to improve energy efficiency and therefore the losses (Opex) of the system should be optimised.

Second step: Assessment of the situation

Harmonic distortion is relevant at the PCC on the MV side of the factory. Therefore, a THD_i of 15% is sufficient for the installation of this pump. The customer wants to compare an AFE solution with a multi-pulse solution.

Third step: Selection of solution

A 12-pulse supply has been selected, based on cost and energy efficiency reasons.

The installation cost (Capex) for an additional 12-pulse transformer*) is roughly the same as for an AFE drive. But efficiency of a 12-pulse drive (incl. transformer) is around 1.5 to 2% better than a AFE drive.

For an 1,200 kW drive, this results in energy savings of up to €11,000 each year and a CO₂ emission saving of 64,000 kg!

**For new installations a transformer is usually needed anyway. In this case the installation cost (Capex) for a 12-pulse solution is a fraction as for an AFE solution!*

● Which solution to adopt for connection of Power Factor Correction capacitors in an existing installation?

Network characteristics, and in particular network background distortion, must absolutely be taken into account when choosing a **Power Factor Correction** system.

Devices using power electronics (Variable Speed Drives, rectifiers, UPS, fluorescent lamps, etc.) generate harmonic currents in electrical networks.

Capacitors are highly sensitive to harmonics and they can also amplify the present harmonic distortion of an installation due to a resonance phenomenon. A high level of harmonic distortion causes capacitors to overheat, leading to premature ageing and possible breakdown.

For existing installations, it is recommended harmonic measurements be performed.

The selection of the appropriate PFC solution is made:

- According to the percentage of total harmonic current distortion THD_i measured at the transformer secondary, at **maximum load and with no capacitor connected**:

THD_i (%)	Classic	Comfort	Harmony	Filters
$\leq 5\%$	█			
$5\% < \dots \leq 10\%$		█		
$10\% < \dots \leq 20\%$			█	
$> 20\%$				█

- According to the percentage of total harmonic voltage distortion THD_u measured at the transformer secondary, at **maximum load and with no capacitor connected**:

THD_u (%)	Classic	Comfort	Harmony	Filters
$\leq 3\%$	█			
$3\% < \dots \leq 4\%$		█		
$4\% < \dots \leq 7\%$			█	
$> 7\%$				█

When contractual emission limits are to be met at the installation level, a harmonic study is required. The possible filter may be of different technologies:

- Active,
- Passive,
- Hybrid.

Varset capacitor banks



Solutions for a machine

- How to design a machine that includes non linear circuits in order to comply with harmonic emission limits?

Two types of machines are distinguished:

- **Catalogued** machine : a standard machine that fits the needs of most of the customers,
- **Special** machine: a machine that is dedicated to an End User with his own specifications.

The compliance with the standards is:

- The responsibility of the OEM but Schneider Electric is ready to provide solutions,
- Not required at the drive level but at the machine level. The main difference is that at the machine level, all the pieces of equipment must be taken into account (linear or non-linear) for the assessment of THD_i.

For **catalogued machines**,

2 questions should be asked to the customer:

Does a machine standard exist?

If **Yes**: compliance to the standard is required.

A typical example is a lift for which the compliance to the product family standard is required (EN12015: "Electromagnetic compatibility. Product family standard for lifts, escalators and passenger conveyors. Emission").

The solution is to use ATV71 "Lift" or ATV31 "Lift" associated with a choke.

Most of the machine standards do not specify harmonic emission limits.

Where is the machine installed (when no machine standard exists)?

- In a **plant** or in **infrastructure**:

There is no requirement at the machine level and, if necessary, the harmonic mitigation has to be done at the installation level.

For drives power above 15kW, Schneider Electric advocates limiting the THD_i at around 50% in order to avoid cables and devices over rating. Altivar ATV 71 and ATV 61 integrate a DC-link choke as a standard, which limits the line current at the same level as the motor current. For high power machines (> 630kW), other solutions are recommended.

- In a **building** (HVAC applications)

- In a single motor machine such as Air Handling Units (AHU), compliance to IEC 61000-3-12 is generally requested. Mitigation has to be done at the drive level. Schneider Electric solution is to use ATV21 that will provide a THD_i down to 30% as a standard.

- Chiller, roof top, cooling tower, are multi-motor machines. A quick simulation could be done by using HarmCalc software to determine whether harmonic mitigation is necessary according to the THD_i calculated.

- Other machines where power is higher than 1kW. Schneider Electric advocates using ATV312 or ATV12: no harmonic mitigation is required.

- Do not know

It is not possible to find a relevant standard that could be applied. The harmonic mitigation, if necessary, is carried out at the installation level.

For special machines, the specification is given by the End User or the system integrator. In order to understand the requirements and propose solutions, it is necessary to get some data on the installation.

Special cases: when the machines or the drives can be supplied by a generator. To ensure the normal operation of the generator, the **THD_i at the generator level** should be limited: the limits are given by the generator specifications.



To know more

Basics on Harmonics

The opposite figure illustrates the typical waveforms of line current and line voltage for a three-phase variable speed drive.

The line current is distorted as a result of the non linearity of the input rectifier. The voltage distortion is the result of the circulation of the distorted current through the line impedance.

In this example, the Total Harmonic Current Distortion THD_i is equal to 40%, and the Total Harmonic Voltage Distortion THD_u is equal to 4.3%. (See definitions below).

The harmonic current spectrum, representing the amplitude of individual harmonic currents I_h (%) is shown on the opposite figure.

The current distortion can be reduced by implementation of harmonic mitigation. As an example, the improvement provided by a 12-pulse arrangement is presented on the opposite figure. THD_i is reduced from 40 to 11%

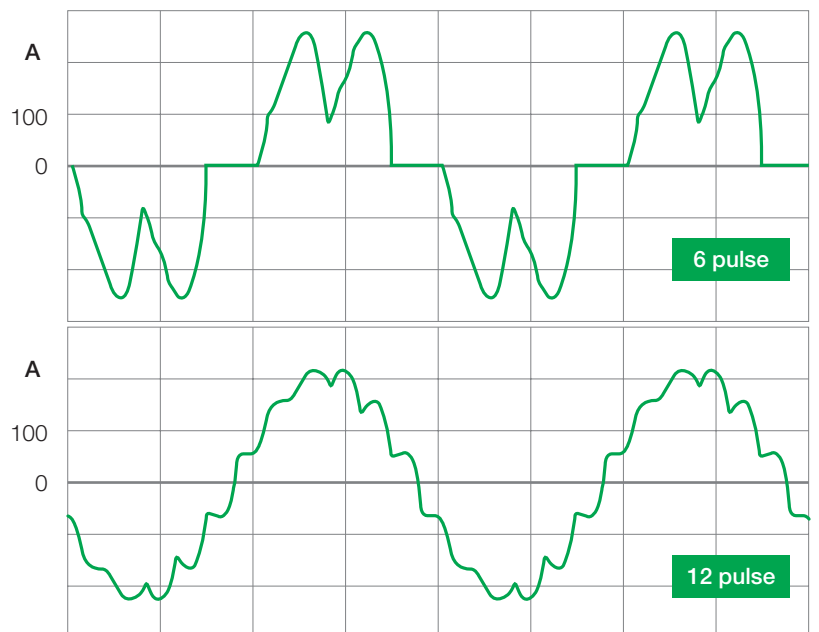
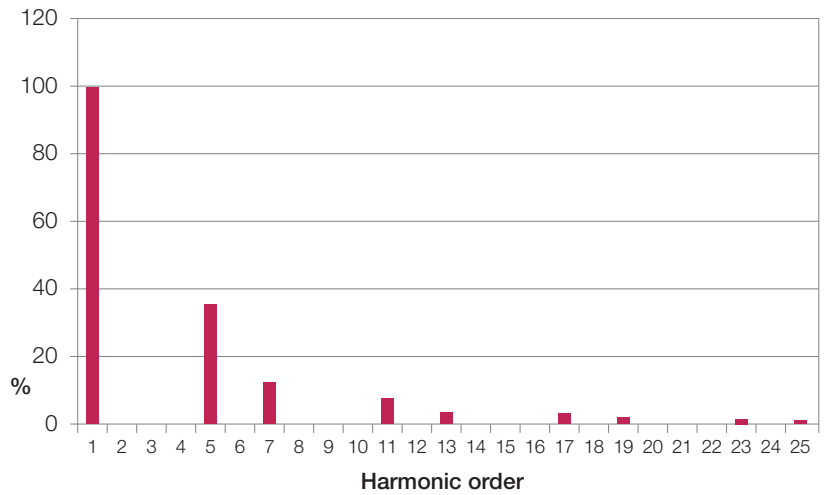
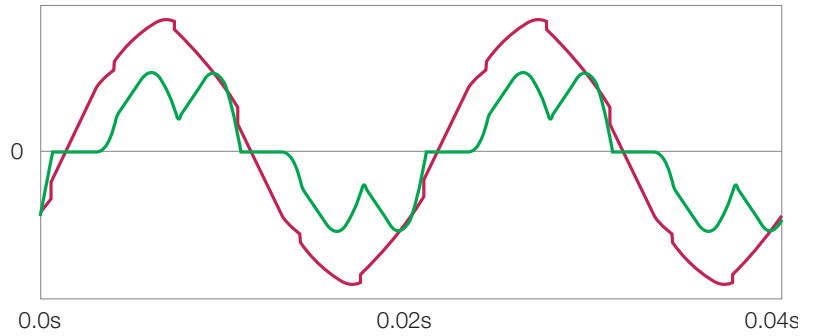

To know more

Definitions

Only the most useful definitions and formulae relative to harmonics are given hereafter. Some numerical values are also provided as illustration.

Power Factor (λ) and Displacement Power Factor ($\cos \varphi$):

The power factor λ is the ratio of the active power P (kW) to the apparent power S (kVA) for a given circuit.

$$\lambda = \frac{P(\text{kW})}{S(\text{kVA})}$$

For the special case of sinusoidal voltage and current with a phase angle φ , the Power Factor is equal to $\cos \varphi$, called Displacement Power Factor.

Total Harmonic Distortion (THD):

Ratio of the r.m.s. value of the sum of all the harmonic components of an alternating quantity up to a specified order (H), to the r.m.s. value of the fundamental component.

$$\text{THD} = \sqrt{\sum_{h=2}^H \left(\frac{Q_h}{Q_1}\right)^2}$$

Q represents either current or voltage. H is generally equal to 40. Higher values (up to 50) are considered in some applications.

The current THD is commonly noted THD_i and is equal to:

$$\text{THD}_i = \sqrt{\sum_{h=2}^H \left(\frac{I_h}{I_1}\right)^2} = \frac{\sqrt{I_2^2 + I_3^2 + \dots + I_{40}^2}}{I_1}$$

From this definition, we can obtain this very useful formula:

$$I_{\text{rms}} = I_1 \cdot \sqrt{1 + \text{THD}_i^2}$$

The voltage THD is commonly noted THD_u and is equal to:

$$\text{THD}_u = \sqrt{\sum_{h=2}^H \left(\frac{U_h}{U_1}\right)^2} = \frac{\sqrt{U_2^2 + U_3^2 + \dots + U_{40}^2}}{U_1}$$

Total demand distortion (TDD):

Ratio of the r.m.s. value of the sum of all the harmonic components, in percent of the maximum demand load current I_L (15 or 30 min demand).

$$\text{TDD} = \sqrt{\sum_{h=2}^H \left(\frac{I_h}{I_L}\right)^2}$$

This variable is used within IEEE 519 to set harmonic emission limits.

Public supply system:

Electrical distribution system operated by a company (Utility) responsible for supplying electricity to customers.

Private network:

Electrical system or installation belonging to a private company, supplied by the local Utility.

Point of Common Coupling (PCC):

Point in the public supply system, which is electrically closest to the installation concerned, at which other installations are, or could be, connected. The PCC is a point located upstream of the considered installation. Most of the time, the PCC is at the MV side of the public network.

The PCC is the location where the THD_u compliance is required.

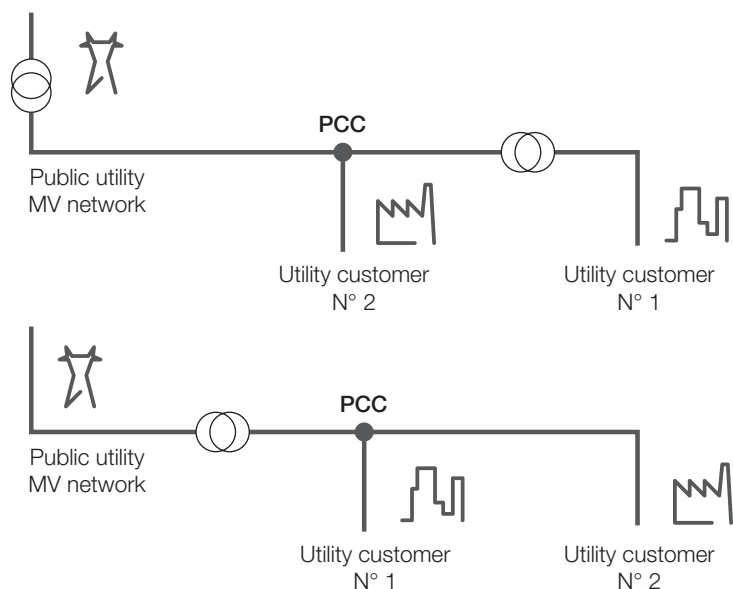

Short-circuit Power (S_{sc}):

Value of the three-phase short-circuit power calculated from the nominal interphase voltage U_{nom} and the line impedance Z of the system at the PCC.

$$S_{sc} = \frac{(U_{nom})^2}{Z}$$

Z is the system impedance at the power frequency. More detailed information on the calculation of Z is given in IEC 61000-2-6: "Assessment of the emission levels in the power supply of industrial plants as regards low-frequency conducted disturbances".

Generally, the short-circuit power S_{sc} at the PCC can be obtained from the Utility.

By considering the transformer impedance only, the short-circuit power can be derived from the transformer impedance Z_T given by the formula:

$$Z_T = \frac{u_{sc}}{100} \times \frac{U_{nom}^2}{S_n}$$

Where:

- S_n is the rated apparent power of the transformer
- u_{sc} is the short-circuit voltage of the transformer (%)

Combining the two formulae, it comes:

$$S_{sc} = \frac{S_n \cdot 100}{u_{sc}}$$

For example: $S_n = 1500\text{kVA}$
 $u_{sc} = 6\%$

Then, $S_{sc} = 25\text{ MVA}$

Short-circuit ratio (R_{sce}):

Characteristic value of a piece of equipment (of rated apparent power S_{equ}) defined by the ratio: $R_{sce} = S_{sc} / S_{equ}$

For example:

- apparent power of a piece of equipment:
 $S_{equ} = 25\text{ kVA}$

- short-circuit power: $S_{sc} = 25\text{ MVA}$

Then, the short-circuit ratio is: $R_{sce} = 1000$

For determination of harmonic emission limits, IEEE 519 is considering the ratio I_{sc} / I_L , where:

- I_{sc} is the short-circuit current at the PCC,
- I_L is the maximum demand load current (fundamental frequency component) at the PCC.

The short-circuit current I_{sc} is linked to the short-circuit power S_{sc} by the formula:

$$S_{sc} = \sqrt{3} \cdot U_{nom} \cdot I_{sc}$$

For a fully loaded installation, the maximum demand load current I_L is close to the transformer rated current. Then:

$$I_L \approx \frac{S_n}{\sqrt{3} \cdot U_{nom}}$$

For example: $S_n = 1500\text{ kVA}$
 $S_{sc} = 25\text{ MVA}$

Then:

$$\frac{I_{sc}}{I_L} \approx \frac{S_{sc}}{S_n} = \frac{25 \cdot 10^6}{1500 \cdot 10^3} = 16.7$$

To know more

Standards

Regarding harmonics, the purpose of standardization is to ensure that the voltage distortion at the PCC is kept sufficiently low, so that other customers connected at the same point are not disturbed. This is the basis of the concept of "Electromagnetic Compatibility" (EMC).

The current industry standards include documents **relative to equipment** and documents **relative to distribution network installations**. All these documents are aimed at limiting interference linked to harmonics.

This means that the objective is to limit the impact of connection of non-linear loads in terms of voltage distortion and avoid unacceptable disturbances applied to neighbouring installations connected to the same supply network. This is the basis of the concept of "compatibility level".

For easier applicability of these documents, limits for generated harmonic currents are given.



Standards relative to individual equipment

The applicable generic international standards are:

- **IEC 61000-3-2:** "Limits for harmonic current emissions, equipment input current $\leq 16A$ per phase",
- **IEC 61000-3-12:** "Limits for harmonic currents produced by equipment connected to public low-voltage systems with input current $> 16A$ and $\leq 75A$ per phase".

These documents apply to equipment connected directly to the Low-Voltage public supply network. They are not applicable to equipment connected in an installation supplied at Medium Voltage by the local Utility. No standard is applicable to equipment connected in a private LV network (installation supplied at MV level by the Utility).

The harmonic current limits have been derived by limiting the voltage distortion produced by a single piece of equipment to a fraction of the maximum acceptable global distortion ("compatibility level").

Variable speed drives are mostly impacted by IEC 61000-3-12 (applicable to equipment with line current $>16A$ and $\leq 75A$), as, per IEC 61000-3-2, no limits are applicable to professional equipment with a rated power $>1kW$ and a line current $<16A$.

Limits are given for harmonic currents (I_h) and total harmonic distortion THD_i . For example, limits for the 5th order harmonic current I_5 and total harmonic distortion THD_i applicable to equipment such as frequency converters with $R_{sce} > 120$ are:

- $I_5 \leq 40\%$
- $THD_i \leq 48\%$

It is possible to comply with these limits when using an AC-line or DC-link reactor.

For variable speed drives, a specific standard has been published: **IEC 61800-3:** "Adjustable speed electrical power drive systems, EMC requirements and specific test methods".

This document refers to IEC 61000-3-2 and IEC 61000-3-12 for application at equipment level on LV public networks.

On industrial networks, or for equipment outside of the scope of IEC 61000-3-2 or 61000-3-12, the suggested reasonable approach is to assess the harmonic emission for the whole installation.

The recommended approach in the different situations is illustrated on the following figure.

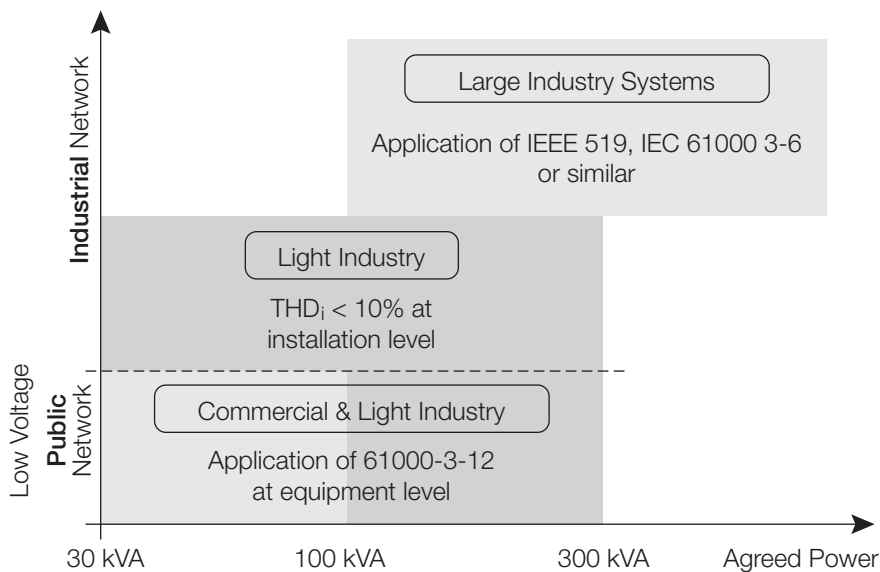

Documents relative to installations

The most relevant documents are listed below:

- **IEEE 519:** "Recommended Practices and Requirements for Harmonic Control in Electrical Power Systems" (1992),
- **IEC 61000-3-6:** "Assessment of emission limits for distorting loads in MV and HV power systems" (2008),
- **Engineering Recommendation G5/4-1:** "Planning levels for harmonic voltage distortion and the connection of non-linear equipment to transmission systems and distribution networks in the United Kingdom" (2001),
- **"Technical rules for the assessment of network disturbances"**, published by Austria, Czech Republic, Germany and Switzerland authorities (2004).
- **"Arrêté du 17 mars 2003** Design and operation technical requirements for connection of electricity consuming installation to the public supply network", France (2003).

Now under development is project **IEC 61000-3-14:** "Assessment of emission limits for the connection of disturbing installations to LV power systems". This future document is the first IEC document for harmonic limitations applicable to LV installations.

All these documents have been elaborated with a strong involvement of the Utilities, as they are aimed at the fulfilment of power quality objectives.

Limits for installations can be also defined by a contractual arrangement or by national regulations (e.g.: in France, UK, ...).

Here are examples of limits given in these documents, and applicable for implementation of non linear loads such as variable speed drives. For simplification, only limits related to the 5th order harmonic and total harmonic distortion are mentioned.

IEEE 519

The derivation of harmonic current limits is based on the objective of voltage distortion at the PCC. Particularly: $V_5 \leq 3\%$ and $THD_u \leq 5\%$.

For installations supplied at LV or MV, considering the short-circuit current I_{SC} and the maximum load demand current I_L , the possible range for the 5th harmonic current is between 4 and 15%, for I_{SC}/I_L varying from 20 to 1000.

In the same conditions, the possible range of TDD is between 5 and 20%.

ER G5/4-1

Limits are given for aggregate loads, per customer. The maximum permissible 5th harmonic current per phase I_5 is 28.9 A. If this limit cannot be met, the predicted system voltage characteristics at the Point of Common Coupling (PCC) after connection should be: $V_5 \leq 4\%$ and $THD_u \leq 5\%$.

To know more

General statement

Standards provide limits for voltage and/or current harmonic levels. It is to be noted that for a given THD_i level, the higher the R_{sce} , the lower the THD_u will be. (See following figure).

On the contrary, considering the maximum authorised THD_u required by standards, the higher the R_{sce} , the higher the THD_i can be allowed.

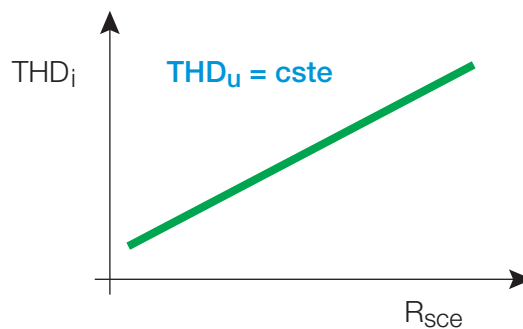
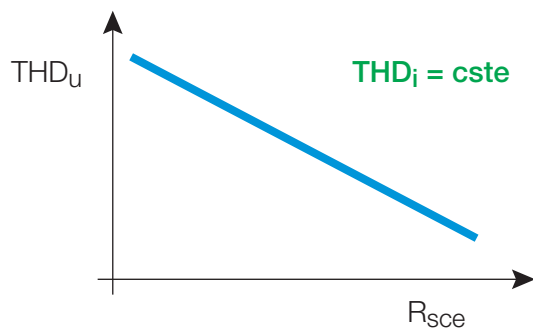

List of documents

- Cahier Technique 152: "Harmonic disturbances in networks, and their treatment"
- Cahier Technique 202: "The singularities of the third harmonic"
- Expert Guide n°4: "Harmonic detection & filtering"
- Expert Guide n°6: "Power Factor Correction and Harmonic Filtering Guide "
- Electrical Installation Guide

Relevant websites

- www.reactivar.com
- <https://www.solution-toolbox.schneider-electric.com/segment-solutions>

Notes

Schneider Electric Industries SAS

35, rue Joseph Monier
F - 92506 Rueil-Malmaison Cedex (France)

Tel: +33 (0)1 41 29 70 00

<http://www.schneider-electric.com>

*As standards, specifications and designs change from time to time,
please ask for confirmation of the information given in this publication.*



Printed on ecological paper.

Layout : Schneider Electric - J. Grison

Photos : Schneider Electric

Printing : imprimerie du Pont de Claix